









The rugged low-power tracker with long battery life with NB-IoT connectivity and guaranteed data recovery. The tracker provides general localization, zone and high precision. The tracker firmware can be upgraded over the air.

-  GNSS
-  Bluetooth geobeacon for zone precision
-  NB-IoT
-  Europe and North America
-  Data recovery
-  IP69K & IP68
-  IK 09
-  Flame retardant

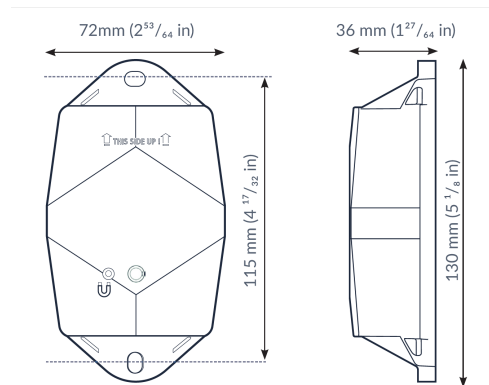

130×72×36 mm
212g (7.6 oz)

Connectivity

NB-IoT

- Energy efficient transceiver
- Internal omnidirectional antenna
- Bi-directional communication
- NB-IoT bands: Europe/North America
- Data recovery
- OTA firmware upgrade (NB-IoT)

Bluetooth Low Energy (BLE)

Bluetooth Low Energy 5.0

Geolocalization

GNSS

Multi GNSS constellation chipset (GPS+GALILEO)

BLE

- Sensolus proximity beacon detection
- Detectable by zone and high precision anchors

Sensing

Internal

- Activity monitoring
- Orientation monitoring
- Virtual tamper detection

Activation and mounting

- Activation manual link
- Holes 7x9mm for screws or rivets. 115 mm distance between the centers of the mounting holes.
- Instructions for mounting the device can be found here.

Mechanics & Design

Antennas

All antennas are internal

Size

130x72x36 mm(LWH)

Weight

212 gram (7.6 oz)

Color

White

Casing

- Shell: PBT + PC Cover: PBT GF30% + TPE
- Flame retardant
- UV-stabilized

Battery

Standard 3 cell

- User replaceable battery pack (Li-SoCl₂) 10500 mAh
- 2.94 gram lithium

Certifications

Regulatory

- CE
- FCC

Electrical safety

EN 62368-1

User Interaction

Device activation

Magnetic activation

Synchronize remote settings

- Instant: Magnet activation
- Periodic: No user interaction needed

Water & dust resistance

IP68 & IP69K

Impact resistance

IK09

Drop shock and vibration

EN 60068

Operating temperature

-20°C to 60°C*

The specifics regarding operational temperature are contingent upon the application, installation circumstances, and environmental factors such as sunlight exposure. For further information, please reach out to Sensolus. Battery life can be affected when devices function for extended periods at the extremes of this range.

Bluetooth 5.0

Declaration ID D068598

LED feedback

Green & red LED feedback on the device

Management Services

Diagnostics

- Battery lifetime prediction
- Detailed energy consumption
- Geolocation diagnostics
- Installation
- Communication quality

Management

- OTA firmware updates over NB-IoT and BLE
- Remote configuration
- Tracker usage profiles

Application services

- Localization
- Journeys
- Activity
- Utilization

Firmware configuration

Communication service

- Data recovery strategy
- Communication conditions

General configuration

- Rule engine configuration
- Diagnostic levels
- Boot methods
- Accurate time synchronization

Activity service

Activity detection parameters

Location service

- Motion based, periodic or scheduled
- Configurable update rate and journey detection
- Priority sequence (GNSS, Bluetooth geobeacon)
- GNSS fix parameters
- Indoor detection algo
- BLE scan strategy

Orientation service

Orientation detection parameters

Tamper service

Virtual tamper algo configuration

Security

- Device unique encryption keys
- End to end payload encryption Chacha 20
- AES encrypted firmware
- Firmware upgrade allows only signed firmware images