

How to install the tracker

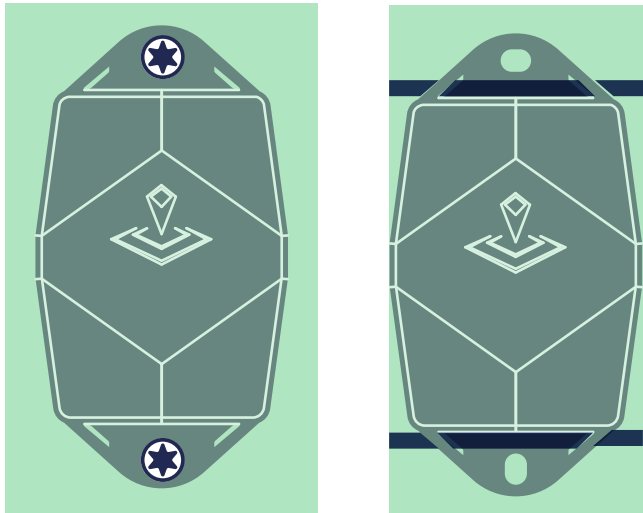

For alternative fixation methods such as magnets, glue and double sided tape please contact the Sensolus Help Desk.

support@sensolus.com or +32.9.298.09.43

Install Tracker with bolts

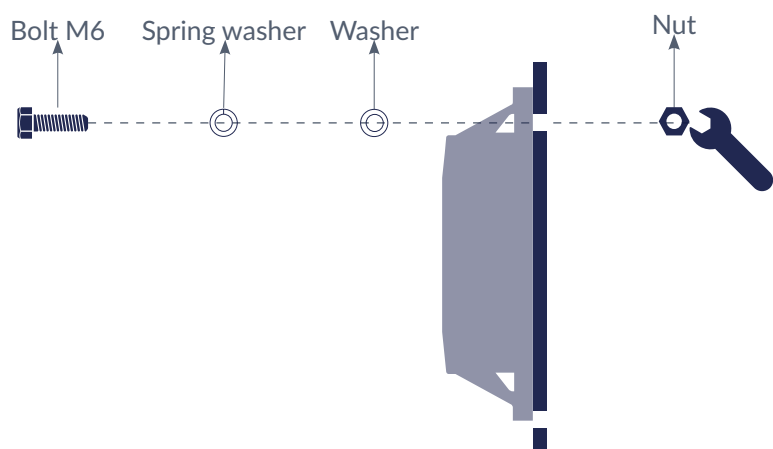

1. Use the appropriate size of screws, it is recommended to use the M6 type and to use thread locking glue on the bolts. We recommend Loctite Thread Locker Blue 242.
2. Protect the tracker casing appropriately: protect the casing with a washer and use a spring washer to mitigate the effects of vibration and temperature variations.
3. Don't apply too much torque during the fixation: the maximum allowed torque is 3.5NM for an M6 screw used with a washer. Applying more torque may severely damage the tracker's casing.

Install Tracker with rivets

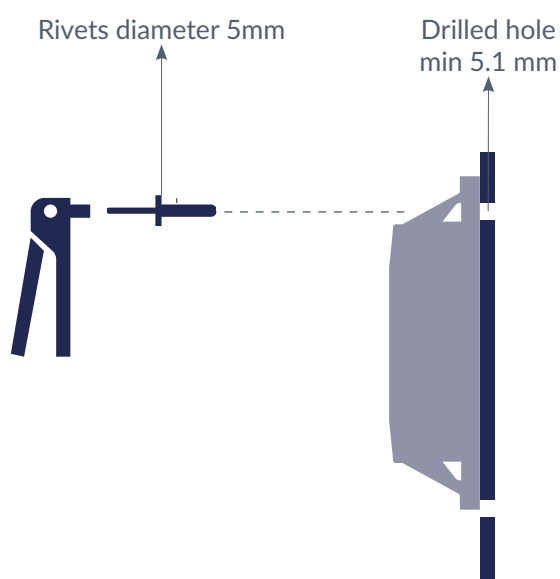

Use the **appropriate size** of rivets.

Choose the right **length** of the rivets.
The height of the casing where the mounting holes are located is 8mm.

We recommended to use rivets with a **diameter** of 5mm.

Installation advice

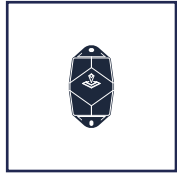

Avoid blocking the tracker's view with metal or carbonfibre walls. They weaken or block the radiofrequency signals.



Place the tracker as high as possible on the asset to ensure good network coverage.

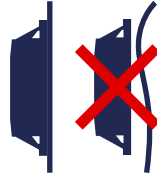

Make sure the mounting surface is **flat and clean**, for a strong and durable bond.



Do not install the tracker on parts that receive frequent shocks or vibrations.



Install the tracker vertically, with the logo facing up.

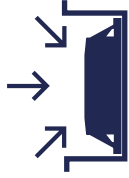

If your asset is handled in a rough environment, you can place the tracker in a protected location, but never with metal or carbonfibre above the tracker.

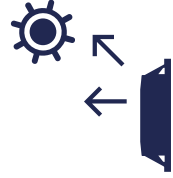

Make sure the tracker has a clear view on the sky.



Avoid placing the tracker in a place that can collect water.



If you can't install vertically, do **not** mount the tracker **upside down**.

Tracker activation

i Activation of the trackers is preferably done with clear skies, and not inside (e.g. factory or warehouse). Trackers are not activated when delivered to your premises. Their subscription in the platform will start within six months of purchase.



Hold a magnet for about 5 seconds on top of the logo on the asset tracker.



You will first see a **red LED**. Do not remove the magnet yet.



When the green LED is blinking you can remove the magnet. Your tracker is ready for use.

Troubleshooting

- Put the magnet on the tracker for less than 5 seconds
- The possible LED feedback options are:



Red LED:
Tracker is not activated



Green LED:
Tracker is activated and working properly



No LED:
tracker is not functioning (probably dead battery -> contact support)



Red LED is blinking:
Tracker is busy

Force new configuration download on the tracker



Hold a magnet for about 5 seconds on top of the logo on the asset tracker.

You will see a green LED.

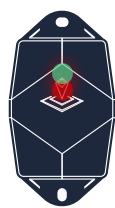

You will see a **red and green LED**.

Now remove the Magnet



Green LED is **blinking** for minimum 30 seconds.

Your tracker is checking for new configurations



You see a red LED:
No new configuration received



You see a green LED: New configuration setting received